

Area and Polygons

MODULE



13



ESSENTIAL QUESTION

How can you find the area of an irregular polygon using area formulas?



LESSON 13.1

Area of Quadrilaterals

 CA CC 6.G.1

LESSON 13.2

Area of Triangles

 CA CC 6.G.1

LESSON 13.3

Solving Area Equations

 CA CC 6.G.1, 6.EE.7

LESSON 13.4

Area of Polygons

 CA CC 6.G.1



Real-World Video

Painting, quilting, and other art forms use familiar geometric shapes, such as triangles and rectangles. To buy enough supplies for a project, you need to find or estimate the areas of each shape in the project.

 my.hrw.com

GO
DIGITAL
my.hrw.com



my.hrw.com

Go digital with your write-in student edition, accessible on any device.



Math On the Spot

Scan with your smart phone to jump directly to the online edition, video tutor, and more.



Animated Math

Interactively explore key concepts to see how math works.



Personal Math Trainer

Get immediate feedback and help as you work through practice sets.

Are YOU Ready?

Complete these exercises to review skills you will need for this module.



Personal
Math Trainer

Online Practice
and Help

my.hrw.com

Inverse Operations

EXAMPLES

$$7k = 35$$

k is multiplied by 7.

$$k + 7 = 9$$

7 is added to *k*.

$$\frac{7k}{7} = \frac{35}{7}$$

Use the inverse operation, division.

$$k + 7 - 7 = 9 - 7$$

Use the inverse operation, subtraction.

$$k = 5$$

$$k = 2$$

Solve each equation using the inverse operation.

1. $9p = 54$ _____ 2. $m - 15 = 9$ _____ 3. $\frac{b}{8} = 4$ _____ 4. $z + 17 = 23$ _____

Metric Units

EXAMPLE

$$6 \text{ m} = \square \text{ cm}$$

Multiply to go from a larger unit to a smaller unit.

$$6 \text{ m} = 600 \text{ cm}$$

$$4,000 \text{ mL} = \square \text{ L}$$

Divide to go from a smaller unit to a larger unit.

$$4,000 \text{ mL} = 4 \text{ L}$$

Convert to the given units.

5. $64 \text{ m} =$ _____ cm 6. $500 \text{ g} =$ _____ kg 7. $4.6 \text{ kL} =$ _____ L

Area of Squares and Rectangles

EXAMPLE

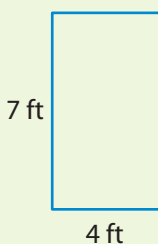

Find the area of the rectangle.

$$A = bh$$

Use the formula for the area of a rectangle.

$$= 7 \times 4$$

Substitute for base and height.

$$= 28$$

The area is 28 square feet.

8. Find the area of a rectangle with a base of 5 feet and a height of $9\frac{1}{2}$ feet _____

Reading Start-Up

Visualize Vocabulary

Use the ✓ words to complete the graphic. You will put one word in each oval.

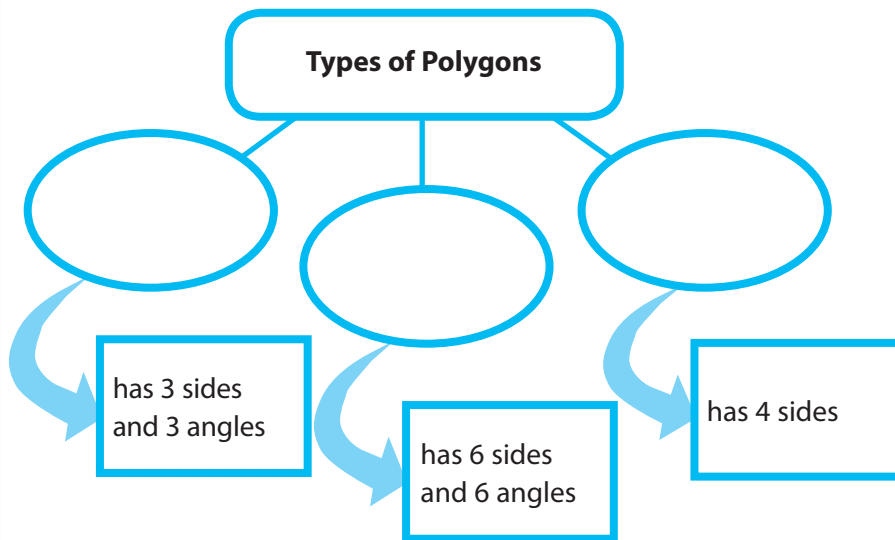

Vocabulary

Review Words

- ✓ hexagon (*hexágono*)
- ✓ polygon (*polígono regular*)
- ✓ quadrilateral (*cuadrilátero*)
 - rectangular prism (*prisma rectangular*)
 - regular polygon (*polígono*)
 - right triangle (*triángulo rectángulo*)
- ✓ triangle (*triángulo*)

Preview Words

- parallelogram (*paralelogramo*)
- rhombus (*rombo*)
- trapezoid (*trapecio*)

Understand Vocabulary

Match the term on the left to the correct expression on the right.

- | | |
|------------------|--|
| 1. parallelogram | A. A quadrilateral in which all sides are congruent and opposite sides are parallel. |
| 2. trapezoid | B. A quadrilateral in which opposite sides are parallel and congruent. |
| 3. rhombus | C. A quadrilateral in which two sides are parallel. |

Active Reading

Pyramid Before beginning the module, create a pyramid to help you organize what you learn. Label each side with one of the lesson titles from this module. As you study each lesson, write important ideas like vocabulary, properties, and formulas on the appropriate side.

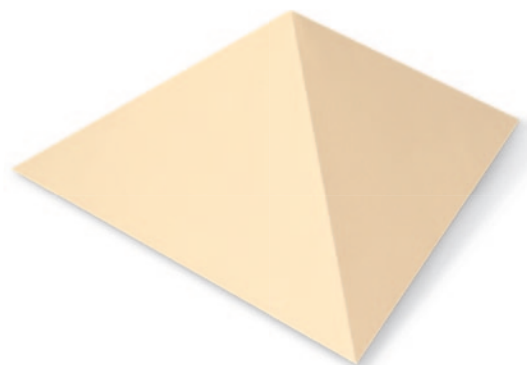



GETTING READY FOR

Area and Polygons

Understanding the standards and the vocabulary terms in the standards will help you know exactly what you are expected to learn in this module.

CA CC 6.G.1

Find the area of right triangles, other triangles, special quadrilaterals, and polygons by composing into rectangles or decomposing into triangles and other shapes; apply these techniques in the context of solving real-world and mathematical problems.

What It Means to You

You will use the formula for the area of a figure to write an equation that can be used to solve a problem.

EXAMPLE 6.G.1

The Hudson Middle School wrestling team won the state tournament and was awarded a triangular pennant to display in the school gymnasium. The pennant has an area of 2.25 square meters. The base of the pennant is 1.5 meters long. Write an equation to find the height of the pennant.

$$A = \frac{1}{2}bh$$

$$2.25 = \frac{1}{2}(1.5)h$$

$$2.25 = 0.75h$$

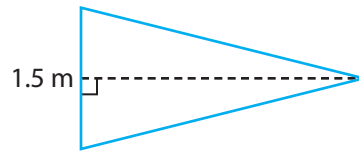

An equation to find the height of the pennant is $2.25 = 0.75h$.

CA CC 6.G.1

Find the area of right triangles, other triangles, special quadrilaterals, and polygons by composing into rectangles or decomposing into triangles and other shapes; apply these techniques in the context of solving real-world and mathematical problems.

What It Means to You

You will use formulas to find the area of irregular polygons.

EXAMPLE 6.G.1

John is measuring his room for new carpet. Find the area of the room.

Find the area of the rectangle.

$$A = bh = 15 \times 6 = 90 \text{ ft}^2$$

Find the area of the square.

$$A = s^2 = 6^2 = 36 \text{ ft}^2$$

The total area is $90 \text{ ft}^2 + 36 \text{ ft}^2 = 126 \text{ ft}^2$.

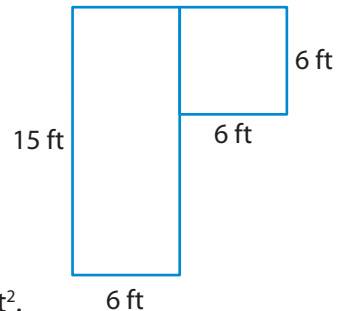

Visit my.hrw.com to see all CA Common Core Standards explained.

my.hrw.com

LESSON 13.1 Area of Quadrilaterals

 **CA CC** 6.G.1

Find the area of right triangles, other triangles, special quadrilaterals, and polygons by composing into rectangles or decomposing into triangles and other shapes; apply these techniques in the context of solving real-world and mathematical problems.



ESSENTIAL QUESTION

How can you find the areas of parallelograms, rhombuses, and trapezoids?

EXPLORE ACTIVITY

 **CA CC** 6.G.1

Area of a Parallelogram

Recall that a rectangle is a special type of parallelogram.

- A** Draw a large parallelogram on grid paper. Cut out your parallelogram.
- B** Cut your parallelogram along the dashed segment as shown. Then move the triangular piece to the other side of the parallelogram.

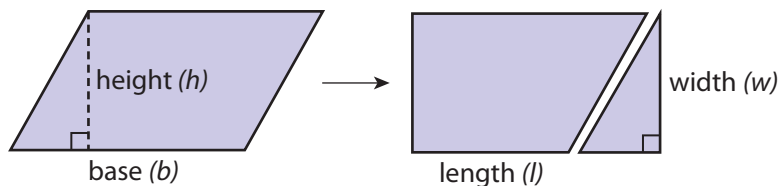

- C** What figure have you formed? _____

Does this figure have the same area as the parallelogram? _____

base of parallelogram = _____ of rectangle

height of parallelogram = _____ of rectangle

area of parallelogram = _____ of rectangle

What is the formula for the area of this figure? $A =$ _____

or _____

- D** What is the formula for the area of a parallelogram? $A =$ _____

Math Talk

 **Mathematical Practices**

Can you use the formula $A = bh$ to find the area of a rectangle? Explain.

Area of a Parallelogram

The area A of a parallelogram is the product of its base b and its height h .

$$A = bh$$

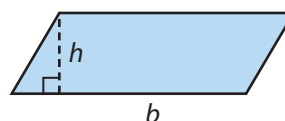

EXPLORE ACTIVITY (cont'd)

Reflect

- Find the area of the parallelogram.

$A =$ _____

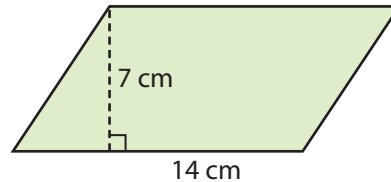

Math On the Spot

my.hrw.com

Finding the Area of a Trapezoid

Notice that two copies of the same trapezoid fit together to form a parallelogram. The height of the parallelogram is the same as the height of the trapezoid. The length of the base of the parallelogram is the sum of the lengths of the two bases (b_1 and b_2) of the trapezoid.

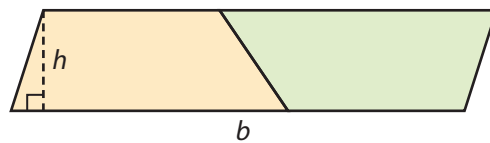

$$\begin{aligned} \text{Area of parallelogram} &= b \cdot h \\ &= (b_1 + b_2) \cdot h \end{aligned}$$

So, the area of a trapezoid is half the area of the parallelogram.

Area of a Trapezoid

The area of a trapezoid is half its height multiplied by the sum of the lengths of its two bases.

$$A = \frac{1}{2}h(b_1 + b_2)$$

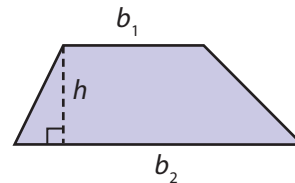

EXAMPLE 1



6.G.1

A section of a deck is in the shape of a trapezoid. What is the area of this section of the deck?

$$b_1 = 17 \quad b_2 = 39 \quad h = 16$$

Use the trapezoid area formula.

$$\begin{aligned} A &= \frac{1}{2}h(b_1 + b_2) \\ &= \frac{1}{2} \cdot 16(17 + 39) && \text{Substitute.} \\ &= \frac{1}{2} \cdot 16(56) && \text{Add inside the parentheses.} \\ &= 8 \cdot 56 && \text{Multiply } \frac{1}{2} \text{ and } 16. \\ &= 448 \text{ square feet} && \text{Multiply.} \end{aligned}$$

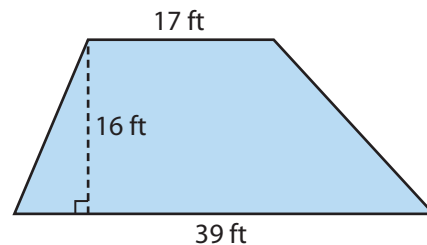

Math Talk



Does it matter which base length is substituted for b_1 and which is substituted for b_2 ? Why or why not?



Animated Math

my.hrw.com

YOUR TURN

2. The length of one base of a trapezoid is 27 feet, and the length of the other base is 34 feet. The height is 12 feet. What is its area? _____



Personal Math Trainer

Online Practice and Help

my.hrw.com



Math On the Spot

my.hrw.com

Finding the Area of a Rhombus

A **rhombus** is a quadrilateral in which all sides are congruent and opposite sides are parallel. A rhombus can be divided into four right triangles that can then be rearranged into a rectangle.

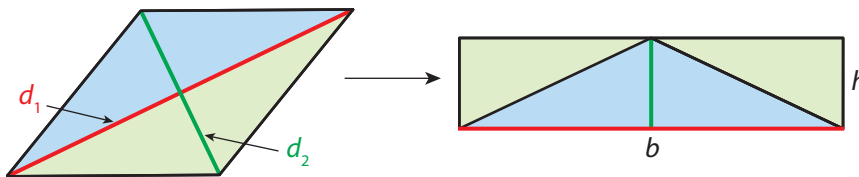

The base of the rectangle is the same length as one of the diagonals of the rhombus. The height of the rectangle is half the length of the other diagonal.

$$A = b \cdot h$$

$$\downarrow \quad \downarrow$$

$$A = d_1 \cdot \frac{1}{2}d_2$$

Area of a Rhombus

The area of a rhombus is half of the product of the lengths of its diagonals.

$$A = \frac{1}{2}d_1d_2$$

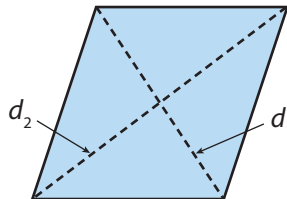

EXAMPLE 2



CA CC 6.G.1

Cedric is constructing a kite in the shape of a rhombus. The spars of the kite measure 15 inches and 24 inches. How much fabric will Cedric need for the kite?

To determine the amount of fabric needed, find the area of the kite.

$$d_1 = 15 \quad d_2 = 24$$

Use the formula for the area of a rhombus.

$$A = \frac{1}{2}d_1d_2$$

$$= \frac{1}{2}(15)(24)$$

Substitute.

$$= 180 \text{ square inches}$$

Multiply.

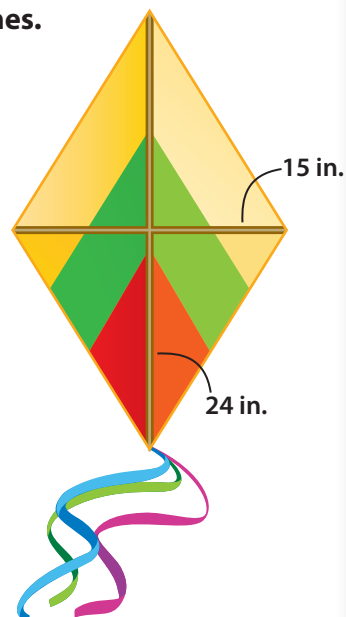

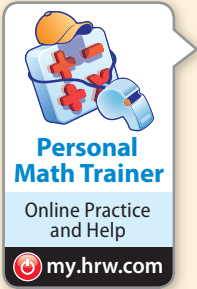

YOUR TURN

Find the area of each rhombus.

3. $d_1 = 35$ m; $d_2 = 12$ m

$A = \underline{\hspace{2cm}}$ m²

4. $d_1 = 9.5$ in.; $d_2 = 14$ in.

$A = \underline{\hspace{2cm}}$ in²

5. $d_1 = 10$ m; $d_2 = 18$ m

$A = \underline{\hspace{2cm}}$ m²

6. $d_1 = 8\frac{1}{4}$ ft; $d_2 = 40$ ft

$A = \underline{\hspace{2cm}}$ ft²

Guided Practice

1. Find the area of the parallelogram. (Explore Activity)

$A = bh$

$= (\underline{\hspace{1cm}})(\underline{\hspace{1cm}})$

$= \underline{\hspace{1cm}}$ in²

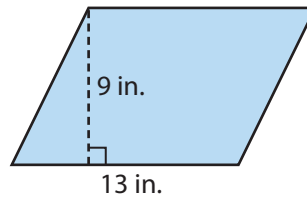

2. Find the area of the trapezoid. (Example 1)

$A = \frac{1}{2}h(b_1 + b_2)$

$= \frac{1}{2}(\square)(\square + \square)$

$= \underline{\hspace{1cm}}$ cm²

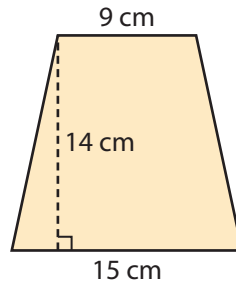

3. Find the area of the rhombus. (Example 2)

$A = \frac{1}{2}d_1d_2$

$= \frac{1}{2}(\square)(\square)$

$= \underline{\hspace{1cm}}$ in²

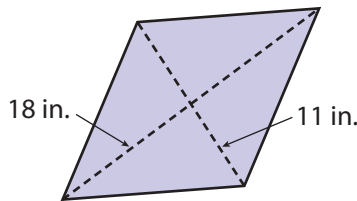

ESSENTIAL QUESTION CHECK-IN

4. How can you find the areas of parallelograms, rhombuses, and trapezoids?

13.1 Independent Practice

 **6.G.1**



Personal Math Trainer

Online Practice and Help

my.hrwc.com

5. Find the area of the parallelogram.

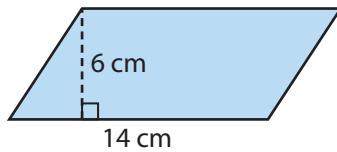

6. What is the area of a parallelogram that has a base of $12\frac{3}{4}$ in. and a height of $2\frac{1}{2}$ in.?

7. Find the area of the trapezoid.

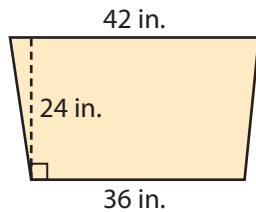

8. The bases of a trapezoid are 11 meters and 14 meters. Its height is 10 meters. What is the area of the trapezoid?

9. Find the area of the rhombus.

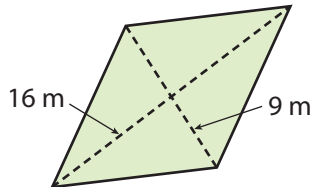

10. The diagonals of a rhombus are 21 m and 32 m. What is the area of the rhombus?

11. The seat of a bench is in the shape of a trapezoid with bases of 6 feet and 5 feet and a height of 1.5 feet. What is the area of the seat?

12. A kite in the shape of a rhombus has diagonals that are 25 inches long and 15 inches long. What is the area of the kite?

13. A window in the shape of a parallelogram has a base of 36 inches and a height of 45 inches. What is the area of the window?

14. **Communicate Mathematical Ideas** Find the area of the figure. Explain how you found your answer.

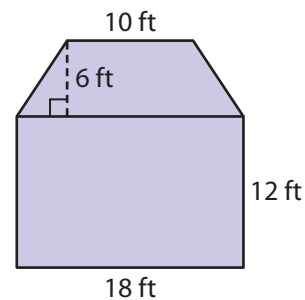

15. **Multistep** A parking space shaped like a parallelogram has a base of 17 feet and a height is 9 feet. A car parked in the space is 16 feet long and 6 feet wide. How much of the parking space is not covered by the car?



FOCUS ON HIGHER ORDER THINKING

16. **Critique Reasoning** Simon says that to find the area of a trapezoid, you can multiply the height by the top base and the height by the bottom base. Then add the two products together and divide the sum by 2. Is Simon correct? Explain your answer.

17. **Multistep** The height of a trapezoid is 8 in. and its area is 96 in.^2 . One base of the trapezoid is 6 inches longer than the other base. What are the lengths of the bases? Explain how you found your answer.

18. **Multiple Representations** The diagonals of a rhombus are 12 in. and 16 in. long. The length of a side of the rhombus is 10 in. What is the height of the rhombus? Explain how you found your answer.

Work Area

LESSON

13.2 Area of Triangles

 **CA CC** 6.G.1

Find the area of right triangles, other triangles, special quadrilaterals, and polygons by composing into rectangles or decomposing into triangles and other shapes; apply these techniques in the context of solving real-world and mathematical problems.



ESSENTIAL QUESTION

How do you find the area of a triangle?

EXPLORE ACTIVITY 1

 **CA CC** 6.G.1

Area of a Right Triangle

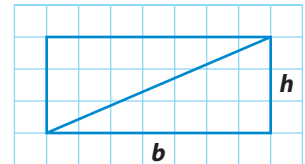

- A** Draw and label a large rectangle on grid paper, as shown.

What is the formula for the area of the rectangle? $A =$ _____

- B** Draw one diagonal of your rectangle.

The diagonal divides the rectangle into _____.

Each triangle's area is _____ the rectangle's area.

Use this information and the formula for area of a rectangle to write a formula for the area of a right triangle. $A =$ _____

Reflect

1. **Communicate Mathematical Ideas** In the formula for the area of a right triangle, what do b and h represent?

EXPLORE ACTIVITY 2

 **CA CC** 6.G.1

Area of a Triangle

- A** Draw a large triangle on grid paper. Do not draw a right triangle.

- B** Cut out your triangle. Then trace around it to make a copy of your triangle. Cut out the copy.

- C** Cut one of your triangles into two pieces by cutting through one angle directly across to the opposite side. Now you have three triangles — one large triangle and two smaller right triangles.

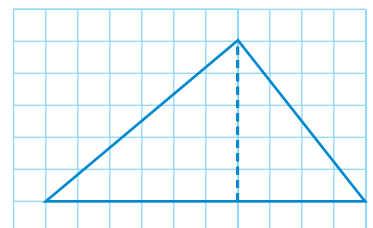

EXPLORE ACTIVITY 2 (cont'd)

When added together, the areas of the two smaller triangles equal the _____ of the large triangle.

- D** Arrange the three triangles into a rectangle.

What fraction of the rectangle does the large triangle represent? _____

The area of the rectangle is $A = bh$. What is the area of the large triangle? $A =$ _____

How does this formula compare to the formula for the area of a right triangle that you found in Explore Activity 1?

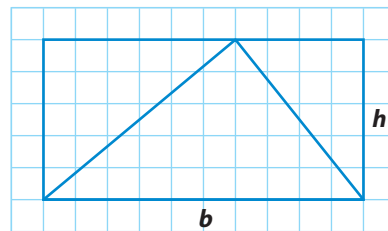

Reflect

2. **Communicate Mathematical Ideas** What type of angle is formed by the base of a triangle and the segment you measure to find the height?



Math On the Spot
my.hrw.com

Finding the Area of a Triangle

Area of a Triangle

The area A of a triangle is half the product of the length of its base b and its height h .

$$A = \frac{1}{2}bh$$

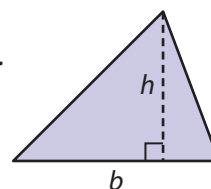

EXAMPLE 1

 CA CC 6.G.1

Find the area of each triangle.

A

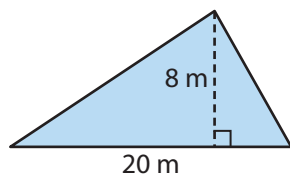

$$b = 20 \text{ meters} \quad h = 8 \text{ meters}$$

$$\begin{aligned} A &= \frac{1}{2}bh \\ &= \frac{1}{2}(20)(8) && \text{Substitute.} \\ &= 80 \text{ square meters} && \text{Multiply.} \end{aligned}$$

Find the area of each triangle.

B

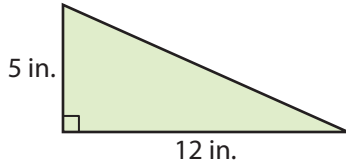

$$b = 12 \text{ inches} \quad h = 5 \text{ inches}$$

$$\begin{aligned} A &= \frac{1}{2}bh \\ &= \frac{1}{2}(12)(5) \\ &= 30 \text{ square inches} \end{aligned}$$

Substitute.

Multiply.

Math Talk

Mathematical Practices



Why can you also write the formula for the area of a triangle as $A = \frac{bh}{2}$?

YOUR TURN

Find the area of the triangle.

3.

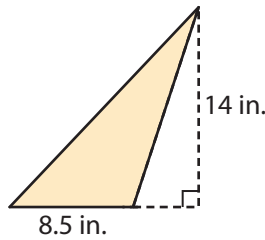

$$A = \underline{\hspace{2cm}}$$

Problem Solving Using Area of Triangles

You can use the formula for the area of a triangle to solve real-world problems.

EXAMPLE 2



CA CC 6.G.1

Each triangular face of the Pyramid of Peace in Kazakhstan is made up of 25 smaller equilateral triangles. These triangles have measurements as shown in the diagram. What is the area of one of the smaller equilateral triangles?

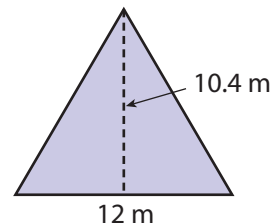

STEP 1

Identify the length of the base and the height of the triangle.

$$b = 12 \text{ m and } h = 10.4 \text{ m}$$

STEP 2

Use the formula to find the area of the triangle.

$$\begin{aligned} A &= \frac{1}{2}bh && \text{Substitute.} \\ &= \frac{1}{2}(12)(10.4) && \text{Multiply.} \\ &= 62.4 \end{aligned}$$

The area of one small equilateral triangle is 62.4 m^2 .



Personal Math Trainer

Online Practice and Help

my.hrw.com



Math On the Spot

my.hrw.com

Reflect

4. **Persevere in Problem Solving** What is the total area of one face of the pyramid? What is the total surface area of the faces of the pyramid, not counting the bottom? (Hint: the bottom of the pyramid is a square.)

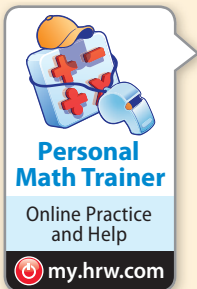

YOUR TURN

5. Amy needs to order a shade for a triangular-shaped window that has a base of 6 feet and a height of 4 feet. What is the area of the shade?

Guided Practice

Find the area of each triangle. (Explore Activities 1 and 2, Example 1)

1.

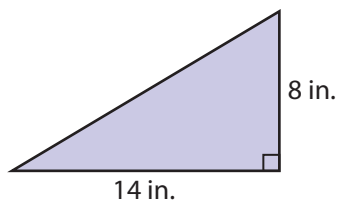

$$\begin{aligned} A &= \frac{1}{2}bh \\ &= \frac{1}{2}(\text{_____})(\text{_____}) \\ &= \text{_____ in}^2 \end{aligned}$$

2. A pennant in the shape of a triangle has a base of 12 inches and a height of 30 inches. What is the area of the pennant? (Example 2)

$$\begin{aligned} A &= \frac{1}{2}bh \\ &= \frac{1}{2}(\text{_____})(\text{_____}) \\ &= \text{_____ in}^2 \end{aligned}$$



ESSENTIAL QUESTION CHECK-IN

3. How do you find the area of a triangle?

13.2 Independent Practice

 **6.G.1**



Personal Math Trainer
Online Practice and Help
my.hrw.com

Find the area of each triangle.

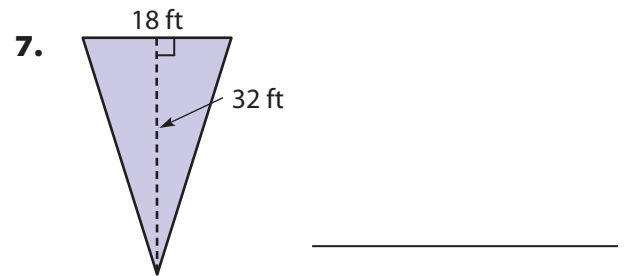
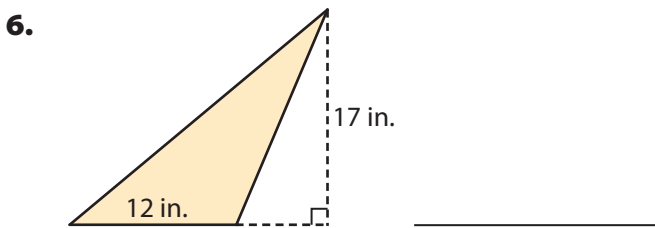
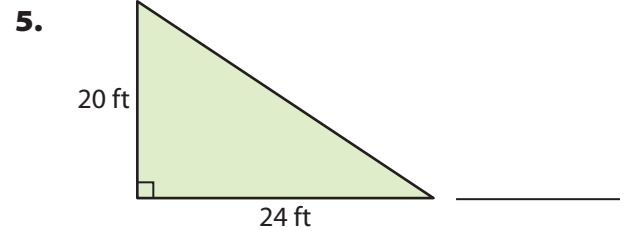
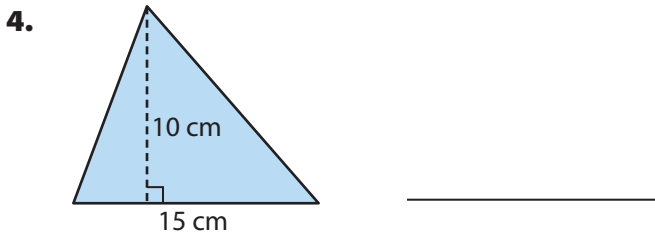

8. What is the area of a triangle that has a base of $15\frac{1}{4}$ in. and a height of 18 in.?

9. A right triangle has legs that are 11 in. and 13 in. long. What is the area of the triangle?

10. A triangular plot of land has the dimensions shown in the diagram. What is the area of the land?

11. The front part of a tent has the dimensions shown in the diagram. What is the area of this part of the tent?

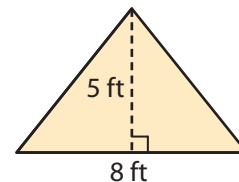
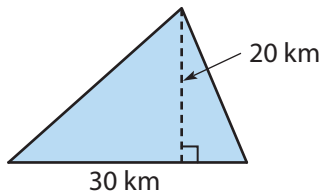

12. **Multistep** The sixth-grade art students are making a mosaic using tiles in the shape of right triangles. The two sides that meet to form a right angle are 3 centimeters and 5 centimeters long. If there are 200 tiles in the mosaic, what is the area of the mosaic?

13. **Critique Reasoning** Monica has a triangular piece of fabric. The height of the triangle is 15 inches and the triangle's base is 6 inches. Monica says that the area of the fabric is 90 in^2 . What error did Monica make? Explain your answer.

14. **Multistep** Wayne is going to paint the side of the house shown in the diagram. What is the area that will be painted? Explain how you found your answer.

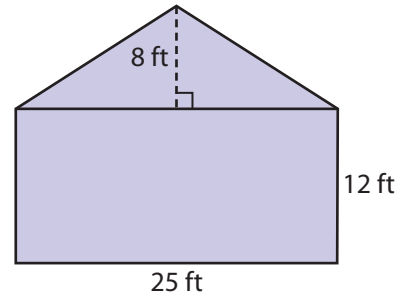

FOCUS ON HIGHER ORDER THINKING

15. **Communicate Mathematical Ideas** Explain how the areas of a triangle and a parallelogram with the same base and height are related.

16. **Analyze Relationships** A rectangle and a triangle have the same area. If their bases are the same lengths, how do their heights compare? Justify your answer.

17. **What If?** A right triangle has an area of 18 square inches.
- a. If the triangle has two sides that are the same length, what are the lengths of these sides?

- b. If the triangle has sides with three different lengths, what are all the possible whole number lengths for the sides that meet at a right angle?

Work Area

LESSON 13.3 Solving Area Equations

 **CA CC** 6.G.1

Find the area of right triangles, other triangles, special quadrilaterals, and polygons by composing into rectangles or decomposing into triangles and other shapes; apply these techniques in the context of solving real-world and mathematical problems. Also 6.EE.7



ESSENTIAL QUESTION

How do you use equations to solve problems about area of rectangles, parallelograms, trapezoids, and triangles?

Problem Solving Using the Area of a Triangle

Recall that the formula for the area of a triangle is $A = \frac{1}{2}bh$. You can also use the formula to find missing dimensions if you know the area and one dimension.



Math On the Spot

 my.hrw.com

EXAMPLE 1



CA CC 6.G.1, 6.EE.7

After winning the state tournament, the wrestling team hangs a pennant shaped like a triangle on the gym wall. The base of the triangle is 1.5 feet long. It has an area of 2.25 square feet. What is the height of the triangle?

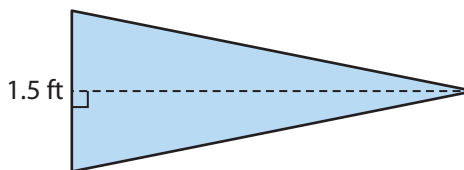

$$A = \frac{1}{2}bh \quad \text{Write the formula.}$$

$$2.25 = \frac{1}{2}(1.5)h \quad \text{Use the formula to write an equation.}$$

$$2.25 = 0.75h \quad \text{Multiply } \frac{1}{2} \text{ and } 1.5.$$

$$\frac{2.25}{0.75} = \frac{0.75h}{0.75} \quad \text{Divide both sides of the equation by } 0.75.$$

$$3 = h$$

The height of the triangle is 3 feet.

Math Talk



Mathematical Practices

How can you use units in the formula to confirm that the units for the height are in feet?

YOUR TURN

1. Renee is sewing a quilt whose pattern contains right triangles. Each quilt piece is a right triangle with a height of 6 inches, and an area of 24 square inches. How long is the base of each quilt piece?



Personal Math Trainer

Online Practice and Help

 my.hrw.com



Math On the Spot

my.hrw.com

Writing Equations Using the Area of a Trapezoid

You can use the formula for the area of a trapezoid to write an equation to solve a problem.

EXAMPLE 2



6.G.1, 6.EE.7

A garden in the shape of a trapezoid has an area of 44.4 square meters. One base is 4.3 meters long and the other base is 10.5 meters long. The height of the trapezoid is the width of the garden. How wide is the garden?

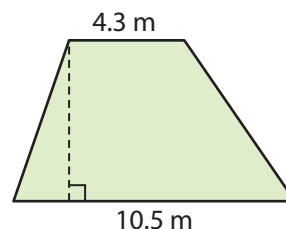

$A = \frac{1}{2} h (b_1 + b_2)$ Write the formula.

$44.4 = \frac{1}{2} h (4.3 + 10.5)$ Use the formula to write an equation.

$44.4 = \frac{1}{2} h (14.8)$ Add inside parentheses.

$44.4 = 7.4 h$ Multiply $\frac{1}{2}$ and 14.8.

$\frac{44.4}{7.4} = \frac{7.4h}{7.4}$ Divide both sides of the equation by 7.4.

$6 = h$

The garden is 6 meters wide.

Reflect

2. **Communicate Mathematical Ideas** Explain why the first step after substituting is addition.

Math Talk

Mathematical Practices

How can you check that the answer is reasonable?



YOUR TURN

3. The cross section of a water trough is shaped like a trapezoid. The bases of the trapezoid are 18 feet and 8 feet long. It has an area of 52 square feet. What is the height of the cross section?



Personal Math Trainer

Online Practice and Help

my.hrw.com

Solving Multistep Problems

You can write and solve equations that represent real-world problems related to relationships in geometry.



EXAMPLE 3

Problem Solving



CA CC 6.G.1

John and Mary are using rolls of fabric to make a rectangular stage curtain for their class play. The rectangular piece of fabric on each roll measures 2.5 feet by 15 feet. If the area of the curtain is 200 square feet, what is the least number of rolls they need?



Analyze Information

Rewrite the question as a statement.

- Find the least number of rolls of fabric needed to cover an area of 200 ft^2 .

List the important information.

- Each roll of fabric is a 2.5 foot by 15 foot rectangle.
- The area of the curtain is 200 square feet.



Formulate a Plan

Write an equation to find the area of each roll of fabric.

Use the area of the curtain and the area of each roll to write an equation to find the least number of rolls.



Solve

STEP 1 Write an equation to find the area of each roll of fabric.

$$A = lw$$

$$A = 15(2.5)$$

$$A = 37.5 \text{ ft}^2$$

STEP 2 Write an equation to find the number of rolls needed.

$$n = 200 \div 37.5$$

$$n = 5\frac{1}{3}$$

STEP 3 The problem asks for the least number of rolls needed. Since 5 rolls will not be enough, they will need 6 rolls to make the curtain.

- The least number of rolls John and Mary will need is 6.



Justify and Evaluate

The area of each roll is about 38 ft^2 . Since $38 \text{ ft}^2 \cdot 6 = 228 \text{ ft}^2$, the answer is reasonable.

My Notes

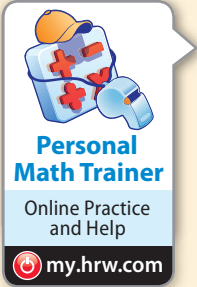

YOUR TURN

4. A parallelogram-shaped field in a park needs sod. The parallelogram has a base of 21.5 meters and a height of 18 meters. The sod is sold in pallets of 50 square meters. How many pallets of sod are needed to fill the field?
- _____

Guided Practice

1. A triangular bandana has an area of 70 square inches. The height of the triangle is $8\frac{3}{4}$ inches. Write and solve an equation to find the length of the base of the triangle. (Example 1)

2. The top of a desk is shaped like a trapezoid. The bases of the trapezoid are 26.5 and 30 centimeters long. The area of the desk is 791 square centimeters. The height of the trapezoid is the width of the desk. Write and solve an equation to find the width of the desk. (Example 2)

3. Taylor wants to paint his rectangular deck that is 42 feet long and 28 feet wide. A gallon of paint covers about 350 square feet. How many gallons of paint will Taylor need to cover the entire deck? (Example 3)

Write and solve an equation to find the _____ of the deck.

Write and solve an equation to find the number of _____.

Taylor will need _____ gallons of paint.



ESSENTIAL QUESTION CHECK-IN

4. How do you use equations to solve problems about area of rectangles, parallelograms, trapezoids, and triangles?

13.3 Independent Practice

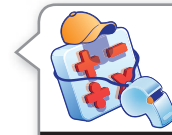

CA CC 6.G.1, 6.EE.7

Personal
Math TrainerOnline Practice
and Help

my.hrw.com

5. A window shaped like a parallelogram has an area of $18\frac{1}{3}$ square feet. The height of the window is $3\frac{1}{3}$ feet. How long is the base of the window?
-
6. A triangular sail has a base length of 2.5 meters. The area of the sail is 3.75 square meters. How tall is the sail?
-
7. A section in a stained glass window is shaped like a trapezoid. The top base is 4 centimeters and the bottom base is 2.5 centimeters long. If the area of the section of glass is 3.9 square centimeters, how tall is the section?
-
8. **Multistep** Amelia wants to paint three walls in her family room. Two walls are 26 feet long by 9 feet wide. The other wall is 18 feet long by 9 feet wide.
- a. What is the total area of the walls that Amelia wants to paint?
-
- b. Each gallon of paint covers about 250 square feet. How many gallons of paint should Amelia buy to paint the walls?
-
9. **Critical Thinking** The area of a triangular block is 64 square inches. If the base of the triangle is twice the height, how long are the base and the height of the triangle?
-
10. **Multistep** Alex needs to varnish the top and the bottom of a dozen rectangular boards. The boards are 8 feet long and 3 feet wide. Each pint of varnish covers 125 square feet and costs \$3.50.
- a. What is the total area that Alex needs to varnish?
-
- b. How much will it cost Alex to varnish all the boards?
-
11. **Multistep** Leia cuts congruent triangular patches with an area of 45 square centimeters from a rectangular piece of fabric that is 18 centimeters long and 10 centimeters wide. How many of the patches can Leia cut from 32 pieces of the fabric?
-
12. **Multistep** A farmer needs to buy fertilizer for two fields. One field is shaped like a trapezoid, and the other is shaped like a triangle. The trapezoidal field has bases that are 35 and 48 yards and a height of 26 yards. The triangular field has the same height as the trapezoidal field and a base of 39 yards. Each bag of fertilizer covers 150 square yards. How many bags of fertilizer does the farmer need to buy?
-

- 13.** A tennis court for singles play is 78 feet long and 27 feet wide.
- The court for doubles play is 9 feet wider than the court for singles play. How much more area is covered by the tennis court used for doubles play?
 - The junior court for players 8 and under is 36 feet long and 18 feet wide. How much more area is covered by the tennis court used for singles play?
 - The length of a court for players 10 and under is 18 feet less than the length of the court for singles play. How much more area is covered by the tennis court used for singles play?

- 14. Draw Conclusions** The cross section of a metal ingot is a trapezoid. The cross section has an area of 39 square centimeters. The top base of the cross section is 12 centimeters. The length of the bottom base is 2 centimeters greater than the top base. How tall is the metal ingot? Explain.

H.O.T. FOCUS ON HIGHER ORDER THINKING

- 15. Analyze Relationships** A mirror is made of two congruent parallelograms as shown in the diagram. The parallelograms have a combined area of $9\frac{1}{3}$ square yards. The height of each parallelogram is $1\frac{1}{3}$ yards.

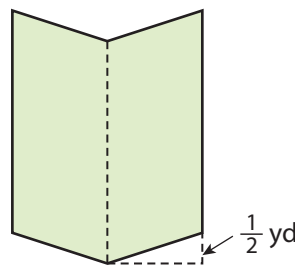

- How long is the base of each parallelogram?
- What is the area of the smallest *rectangle* of wall that the mirror could fit on?

- 16. Persevere in Problem Solving** A watercolor painting is 20 inches long by 9 inches wide. Ramon makes a border around the watercolor painting by making a mat that adds 1 inch to each side of the length and the width. What is the area of the mat?

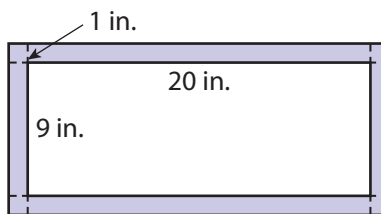

Work Area

13.4 Area of Polygons

Find the area of right triangles, other triangles, special quadrilaterals, and polygons by composing into rectangles or decomposing into triangles and other shapes; apply these techniques in the context of solving real-world and mathematical problems.



ESSENTIAL QUESTION

How can you find the area of a polygon by breaking it into simpler shapes?

EXPLORE ACTIVITY

Finding Areas Using Tangrams

A tangram is a square that is divided into smaller shapes. The area of the small square is 1 square unit. Use a tangram to find the area of each of the other tangram pieces.

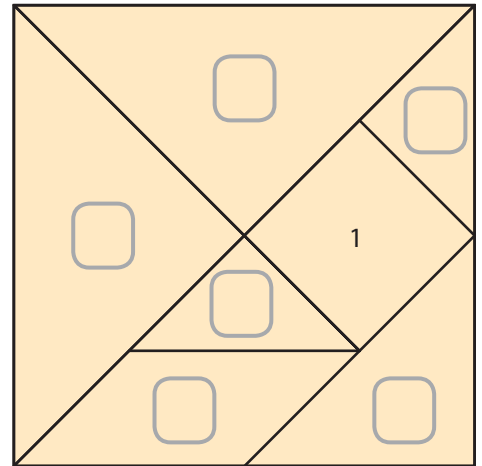

- A** Place one large triangle on top of the other large triangle. What is true about these two triangles? What does this mean about the areas of these two triangles?

- B** Place the two small triangles on top of the square. What is the area of each small triangle? Write this area on the diagram.

- C** Arrange the square and one of the small triangles as shown.

What is the combined area? _____

Place the parallelogram and the other small triangle on top of the combined square and triangle. What is the area of the parallelogram? Explain.

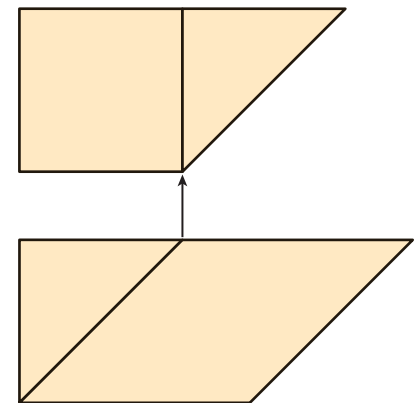

Reflect

1. **Critical Thinking** Complete the rest of the diagram by filling in the remaining areas. Explain how you found your answers.



Math On the Spot

my.hrw.com

Finding Areas of Polygons

You can find the areas of polygons by breaking the polygons into smaller shapes. Then you can apply area formulas you already know.

EXAMPLE 1

CA CC 6.G.1

Find the area of each polygon.

- A** **STEP 1** Draw a horizontal line segment on the diagram that divides the polygon into a rectangle and a triangle.

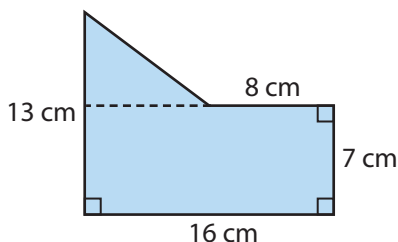

- STEP 2** Find the area of the rectangle.

$$A = bh = 16 \cdot 7 = 112 \text{ square centimeters}$$

- STEP 3** Find the area of the triangle.

$$b = 16 - 8 = 8 \quad h = 13 - 7 = 6$$

$$A = \frac{1}{2}bh = \frac{1}{2} \cdot 8 \cdot 6 = 24 \text{ square centimeters}$$

- STEP 4** Add the areas from Steps 2 and 3 to find the total area.

$$A = 112 + 24 = 136 \text{ square centimeters}$$

- B** **STEP 1** Extend the top edge and the right edge of the polygon to form a square with side length 60 feet. Find the area of this square.

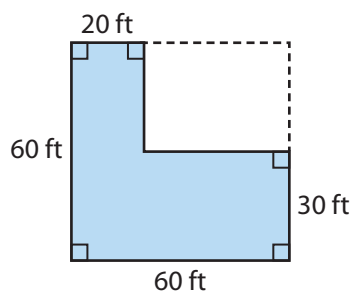

$$60 \cdot 60 = 360 \text{ square feet}$$

- STEP 2** Notice that the square you drew has a rectangular "missing piece." Find the area of this missing piece.

$$b = 60 - 20 = 40 \quad h = 60 - 30 = 30$$

$$A = bh = 40 \cdot 30 = 120 \text{ square feet}$$

- STEP 3** Subtract the area in Step 2 from the area in Step 1.

$$A = 360 - 120 = 240 \text{ square feet}$$

Reflect

2. Describe another way to find the area of the polygon in **B**.

YOUR TURN

Find the area of each polygon.

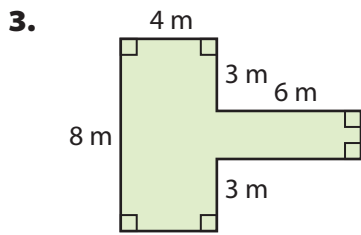

$A =$ _____ square meters

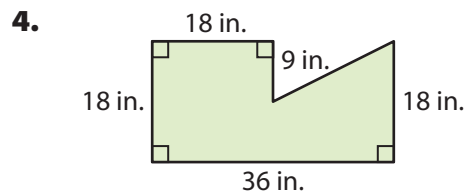

$A =$ _____ square inches



**Personal
Math Trainer**

Online Practice
and Help

my.hrw.com

Solving Real-World Problems

You can apply the technique of dividing a shape into smaller shapes in problems that involve finding area.

EXAMPLE 2



6.G.1

The diagram shows the shape and dimensions of Teresa's rose garden.

A Find the area of the garden.

STEP 1 Draw a horizontal line segment on the diagram that divides the polygon into two rectangles, one on top of the other.

STEP 2 Find the area of the smaller (top) rectangle.

$$A = bh = 15 \cdot 9 = \mathbf{135} \text{ square feet}$$

STEP 3 Find the area of the larger (bottom) rectangle.

The base of the larger rectangle is 24 feet.

The height is $18 - 9 = 9$ feet.

$$A = bh = 24 \cdot 9 = \mathbf{216} \text{ square feet}$$

STEP 4 Add the areas from Steps 2 and 3 to find the total area.

$$A = \mathbf{135} + \mathbf{216} = 351 \text{ square feet}$$

The area of the garden is 351 square feet.

B Teresa wants to buy mulch for her garden. One bag of mulch covers 12 square feet. How many bags will she need?

$$\frac{351 \text{ square feet}}{12 \text{ square feet}} = 29.25 \quad \text{Divide to find the number of bags needed.}$$

Teresa will need to buy 30 bags of mulch.

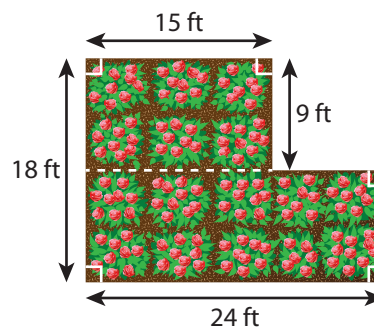

Math On the Spot

my.hrw.com

My Notes

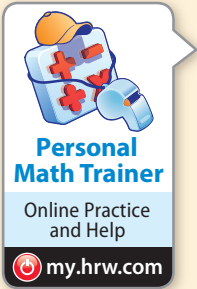

YOUR TURN

5. The diagram shows the floor plan of a hotel lobby. Carpet costs \$3 per square foot. How much will it cost to carpet the lobby?

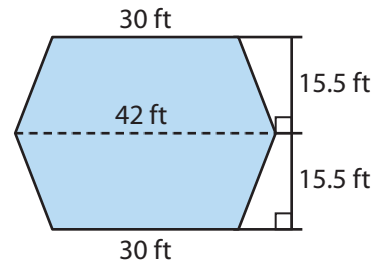

Guided Practice

1. In the diagram, the area of the large square is 1 square unit. Two diagonal segments divide the square into four equal-sized triangles. Two of these triangles are divided into smaller red and blue triangles that all have the same height and base length. Find the area of a red triangle. ([Explore Activity](#))

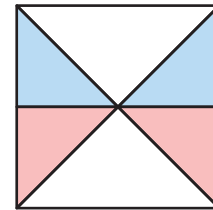

Find the area of each polygon. ([Example 1](#))

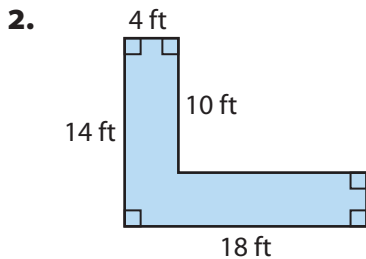

$A =$ _____ square feet

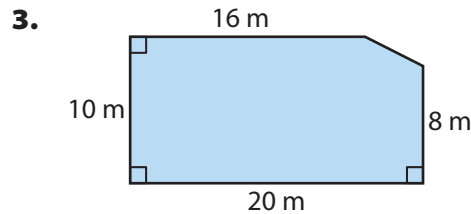

$A =$ _____ square meters

4. Jess is painting a giant arrow on a playground. Find the area of the giant arrow. If one can of paint covers 100 square feet, how many cans should Jess buy? ([Example 2](#))

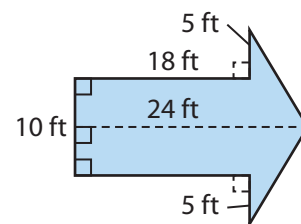

ESSENTIAL QUESTION CHECK-IN

5. How can you find the area of a polygon that is not one for which you know an area formula?

13.4 Independent Practice

CA CC 6.G.1



Personal Math Trainer
Online Practice and Help

my.hrw.com

6. Alice wants to put wall-to-wall carpeting in a small room with the floor plan shown.

a. Alice says she can find the area of the room by dividing the floor plan into two trapezoids. Show how she can divide the floor plan. Then find the area using her method.

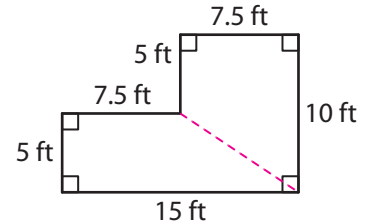

b. Describe another way to find the area.

c. How much will Alice pay for carpet that costs \$4.50 per square foot?

7. Hal's backyard has a patio, a walkway, and a garden.

a. About what percent of the total area of Hal's backyard is the area taken up by the patio, walkway, and garden? Round to the nearest whole percent.

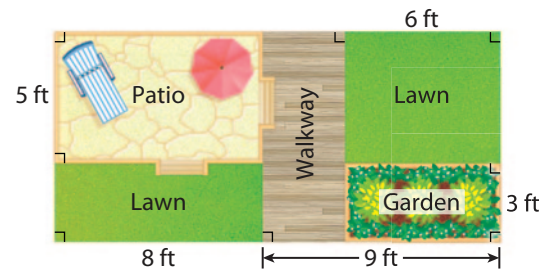

b. One longer side of Hal's backyard lies next to the back of his house. Hal wants to build a fence that costs \$9.75 per foot around the other three sides. How much will Hal spend on his new fence?

8. The students in a furniture-making class make a tabletop shaped like the figure shown. The tabletop has squares cut out of the corners.

a. What is the area of the tabletop?

b. One of the students wants to make a tabletop shaped like a right triangle. This tabletop will have the same area as the tabletop shown. What are a set of possible lengths for the sides that meet in a right angle on this tabletop? Explain.

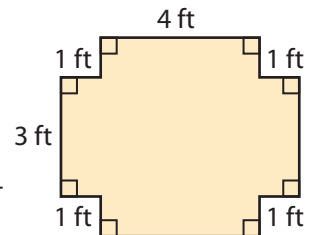

9. **Multistep** Cho is making banners shaped like triangles out of a rectangular piece of fabric. She cuts out two triangular banners as shown.

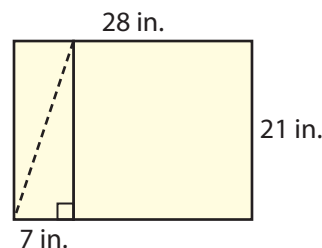

- a. What is the area of a triangular banner?

- b. What are the dimensions of the fabric left over after Cho cuts out the two banners?

- c. What is the maximum number of banners that Cho can cut out from the fabric? Will she use all the fabric?

H.O.T. FOCUS ON HIGHER ORDER THINKING

10. **Persevere in Problem Solving** The base of a parallelogram is 8 units, and the height is 5 units. A segment divides the parallelogram into two identical trapezoids. The height of each trapezoid is 5 units. Draw the parallelogram and the two trapezoids on the grid shown. Then find the area of one of the trapezoids.

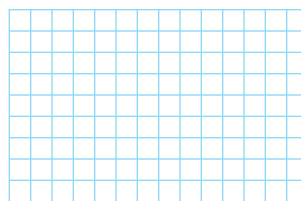

11. **Persevere in Problem Solving** The figure shown is a square with a triangular hole cut into one side. The ratio of the height h of the triangle to a side length of the square is 7 to 8. The ratio of the base b of the triangle to the side length of the square is 1 to 2. If the area of the square is 64 square inches, what is the area of the shaded part of the square? Show your work.

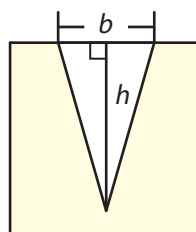

Work Area

Ready to Go On?



Personal Math Trainer
Online Practice and Help
my.hrw.com

13.1 Area of Quadrilaterals

1. Find the area of the figure.

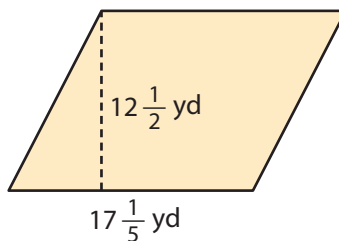

13.2 Area of Triangles

2. Find the area of the triangle.

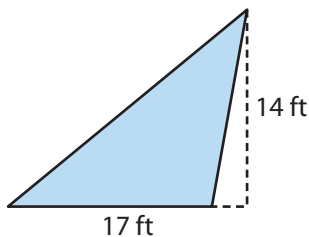

13.3 Solving Area Equations

3. A triangular pane of glass has a height of 30 inches and an area of 270 square inches. What is the length of the base of the pane?

4. A tabletop in the shape of a trapezoid has an area of 6,550 square centimeters. Its longer base measures 115 centimeters, and the shorter base is 85 centimeters. What is the height?

13.4 Area of Polygons

5. Find the area of the polygon.

_____ square centimeters

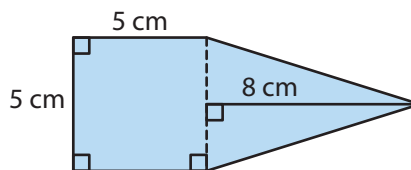

ESSENTIAL QUESTION

6. How can you find the area of an irregular polygon using area formulas?



1. The base of a rectangle is 3 centimeters long and its height is half the base length. A diagonal divides the rectangle into two identical triangles.

Select Yes or No to answer each question.

- A. Is the area of each triangle 9 cm^2 ? Yes No
- B. Is the area of the rectangle 4.5 cm^2 ? Yes No
- C. Is there enough information given so you could find the perimeter of the rectangle? Yes No

2. In the triangle shown, the ratio of the height to the length of the base is $3 : 4$.

Choose True or False for statements A–C.



- A. The area of the triangle is twice the area of a parallelogram with the same base and height. True False
- B. The height is $\frac{3}{4}$ the base length. True False
- C. The area is 8.64 mm^2 . True False
3. The diagonals of a rhombus are 23 inches and 28 inches long. Luke notices that the diagonals divide the rhombus into four right triangles. Explain how he can find the area of the rhombus using the four triangles.

4. Cindy is designing a rectangular fountain in the middle of a courtyard. The rest of the courtyard will be covered in stone. The part of the courtyard that will be covered in stone has an area of 246 square feet.

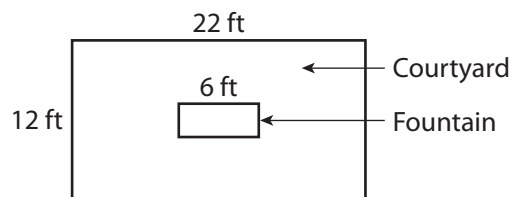

- a. What is the width of the fountain? Show your work.
- b. What fraction of the courtyard will be occupied by the fountain? Explain.